

RF MOSFET Power Transistor, 60W, 12V

2 - 175 MHz

DU1260T

V2.00

Features

- N-Channel Enhancement Mode Device
- DMOS Structure
- Lower Capacitances for Broadband Operation
- High Saturated Output Power
- Lower Noise Figure Than Bipolar Devices
- Specifically Designed for 12 Volt Applications

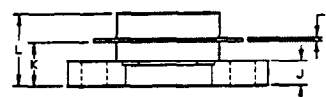
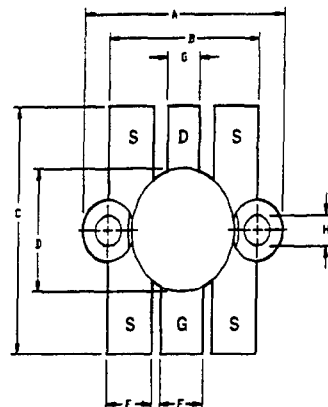

Absolute Maximum Ratings at 25°C

Parameter	Symbol	Rating	Units
Drain-Source Voltage	V_{DS}	40	V
Gate-Source Voltage	V_{GS}	20	V
Drain-Source Current	I_{DS}	24	A
Power Dissipation	P_D	250	W
Junction Temperature	T_J	200	°C
Storage Temperature	T_{STG}	-55 to +150	°C
Thermal Resistance	θ_{JC}	0.7	°C/W

LETTER DIM	MILLIMETERS		INCHES	
	MIN	MAX	MIN	MAX
A	24.38	25.15	.960	.990
B	18.29	18.54	.720	.730
C	21.36	21.74	.841	.856
D	12.60	12.85	.496	.506
E	5.33	5.59	.210	.220
F	5.08	5.33	.200	.210
G	3.81	4.06	.150	.160
H	3.10	3.15	.122	.128
J	2.51	2.67	.099	.105
K	4.06	4.57	.160	.180
L	6.68	7.49	.263	.295
M	.10	.15	.004	.006

Electrical Characteristics at 25°C

Parameter	Symbol	Min	Max	Units	Test Conditions
Drain-Source Breakdown Voltage	BV_{DSS}	40	-	V	$V_{GS}=0.0\text{ V}, I_{DS}=30.0\text{ mA}$
Drain-Source Leakage Current	I_{DSS}	-	6.0	mA	$V_{DS}=15.0\text{ V}, V_{GS}=0.0\text{ V}$
Gate-Source Leakage Current	I_{GSS}	-	6.0	μA	$V_{GS}=20\text{ V}, V_{DS}=0.0\text{ V}$
Gate Threshold Voltage	$V_{GS(TH)}$	2.0	6.0	V	$V_{DS}=10.0\text{ V}, I_{DS}=600\text{ mA}$
Forward Transconductance	G_M	3.0	-	S	$V_{DS}=10.0\text{ V}, I_{DS}=6000\text{ mA}, \Delta V_{GS}=1.0\text{ V}$
Input Capacitance	C_{ISS}	-	200	pF	$V_{DS}=12.0\text{ V}, F=1.0\text{ MHz}$
Output Capacitance	C_{OSS}	-	240	pF	$V_{DS}=12.0\text{ V}, F=1.0\text{ MHz}$
Reverse Capacitance	C_{RSS}	-	48	pF	$V_{DS}=12.0\text{ V}, F=1.0\text{ MHz}$
Power Gain	G_P	8.0	-	dB	$V_{DS}=12.0\text{ V}, I_{DO}=600\text{ mA}, P_{OUT}=60\text{ W}, F=175\text{ MHz}$
Drain Efficiency	η_D	60	-	%	$V_{DS}=12.0\text{ V}, I_{DO}=600\text{ mA}, P_{OUT}=60\text{ W}, F=175\text{ MHz}$
Load Mismatch Tolerance	VSWR-T	-	30:1	-	$V_{DS}=12.0\text{ V}, I_{DO}=600\text{ mA}, P_{OUT}=60\text{ W}, F=175\text{ MHz}$

Specifications Subject to Change Without Notice.

M/A-COM, Inc.

North America: Tel. (800) 366-2266
Fax (800) 618-8883

■ Asia/Pacific: Tel. +81 (03) 3226-1671
Fax +81 (03) 3226-1451

■ Europe: Tel. +44 (1344) 869 595
Fax +44 (1344) 300 020

Typical Broadband Performance Curves

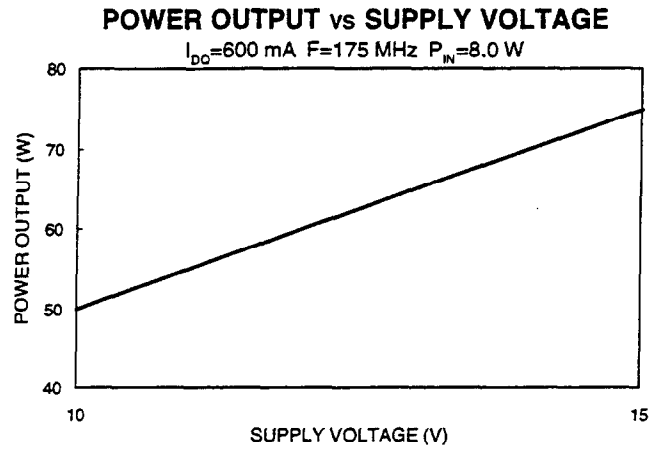
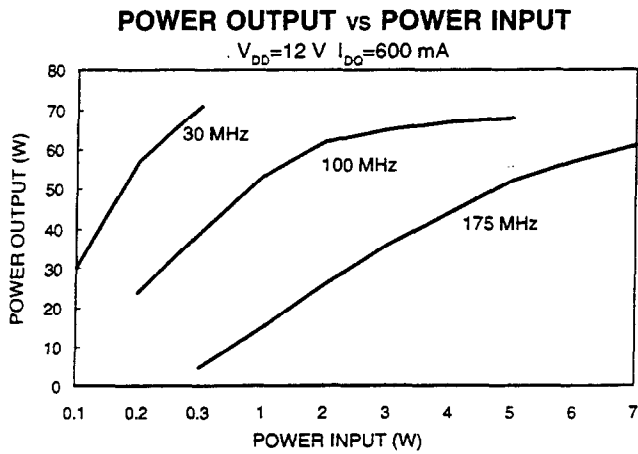
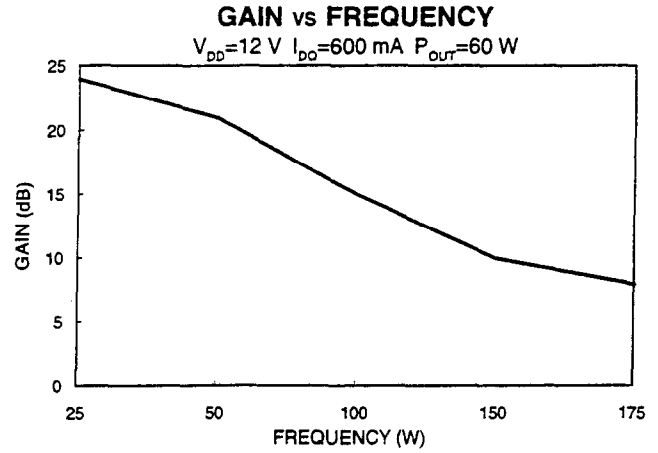
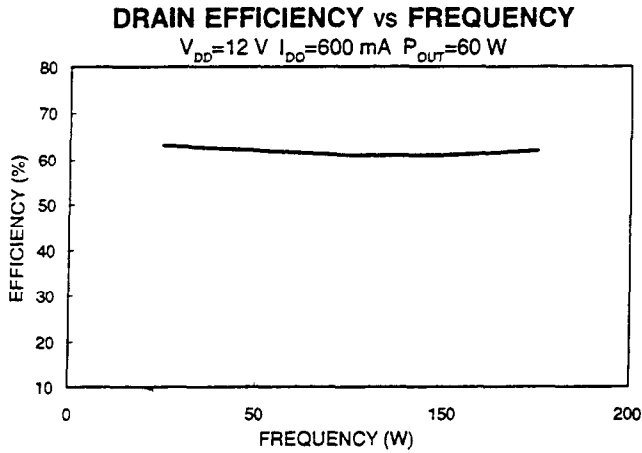

Specifications Subject to Change Without Notice.

M/A-COM, Inc.

North America: Tel. (800) 366-2266
 Fax (800) 618-8883

Asia/Pacific: Tel. +81 (03) 3226-1671
 Fax +81 (03) 3226-1451

Europe: Tel. +44 (1344) 869 595
 Fax +44 (1344) 300 020

Typical Device Impedance

Frequency (MHz)	Z _{IN} (OHMS)	Z _{LOAD} (OHMS)
30	4.5 - j 8.0	4.6 - j 7.9
100	1.4 - j 4.0	1.4 - j 8.0
175	1.0 - j 0.5	1.0 - j 0.5

V_{DD}=12 V, I_{DQ}=600 mA, P_{OUT}=60 Watts

Z_{IN} is the series equivalent input impedance of the device from gate to source.

Z_{LOAD} is the optimum series equivalent load impedance as measured from drain to ground.

RF Test Fixture

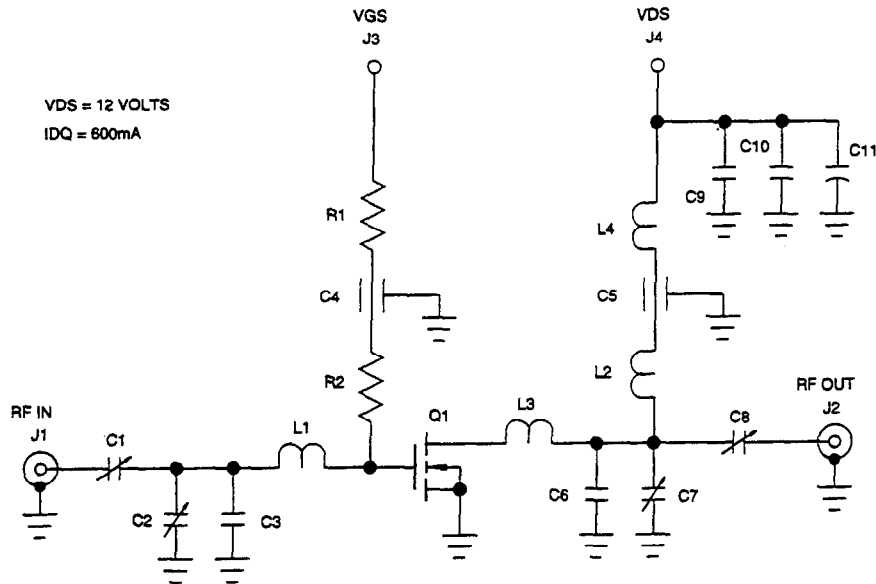

VDS = 12 VOLTS
IDQ = 600mA

PARTS LIST

- C1,C8 ARCO NO. 462 TRIMMER CAPACITOR 5-80pF
- C2,C7 ARCO NO. 422 TRIMMER CAPACITOR 4-40pF
- C3 SEMCO CAPACITOR 50pF
- C4,C5 FEEDTHROUGH CAPACITOR 0.001uF
- C6 SEMCO CAPACITOR 30pF
- C9 SEMCO CAPACITOR 1000pF
- C10 MONOLITHIC CERAMIC CAPACITOR 0.01uF
- C11 ELECTROLYTIC CAPACITOR 50uF 50 V.
- L1,L3 NO. 12 AWG COPPER WIRE X 1"
- L2 8 TURNS OF NO. 20 AWG ENAMEL WIRE ON '0.25", CLOSE WOUND
- L4 12 TURNS OF NO. 20 AWG ON '0.25", CLOSE WOUND
- R1,R2 RESISTOR 100K OHMS
- Q1 DU1260T
- BOARD FR4 0.062"

Specifications Subject to Change Without Notice.

M/A-COM, Inc.

North America: Tel. (800) 366-2266
Fax (800) 618-8883

Asia/Pacific: Tel. +81 (03) 3226-1671
Fax +81 (03) 3226-1451

Europe: Tel. +44 (1344) 869 595
Fax +44 (1344) 300 020